

Spare parts for CH cylinders - big bore sizes

1 EXPLODED VIEW OF THE CYLINDER

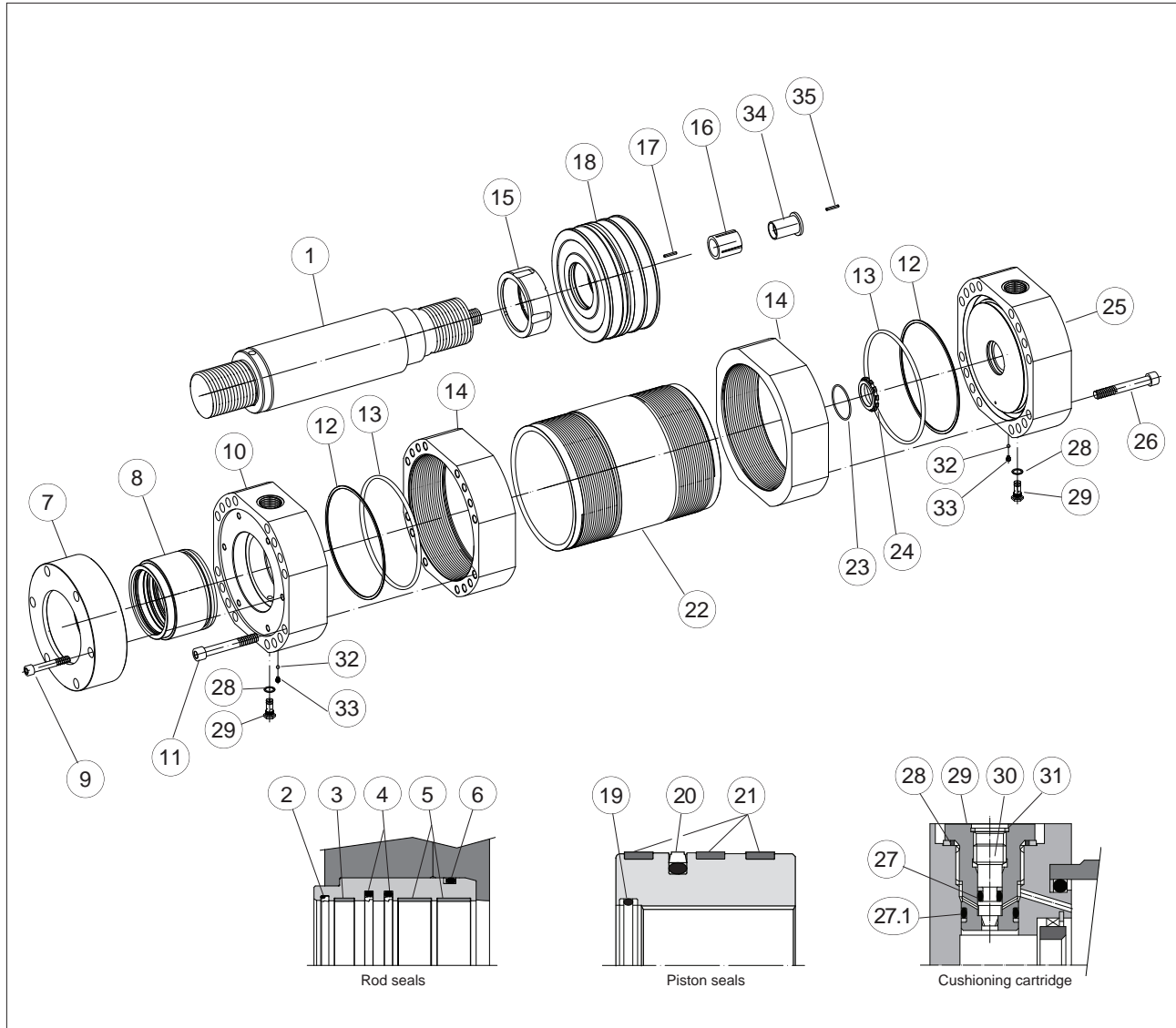

POS	DESCRIPTION	POS	DESCRIPTION
1	Rod	19	O-Ring + Anti-extrusion ring
2	Wiper	20	Piston seal
3	Rod guide ring	21	Piston guide ring
4	Rod seal	22	Cylinder housing
5	Rod guide ring	23	Toroidal ring
6	O-Ring + Anti-extrusion ring	24	Rear cushioning sleeve
7	Flange	25	Rear head
8	Rod bearing	26	Screw
9	Screw	27	O-Ring + Anti-extrusion ring
10	Front head	27.1	O-Ring + Anti-extrusion ring
11	Screw	28	Bonded seal
12	Anti-extrusion ring	29	Cushioning adjustment plug
13	O-ring	30	Cushioning adjustment screw
14	Counterflange	31	Seeger
15	Front cushioning piston	32	Steel sphere - air bleed
16	Rear cushioning piston	33	Grub screw - air bleed
17	Screw stop pin	34	Rear ring cushioning piston
18	Piston	35	Screw stop pin

2 ASSEMBLING TOOLS

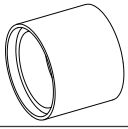
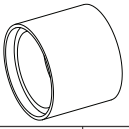
		KP - XX BORE SIZE	KP - XX ROD DIAMETER		
					
ASSEMBLING OPERATION	CYLINDER SIZE	TOOL	TOOL DIMENSION	TORQUE [Nm]	
Cushioning adjustment cartridge (pos. 29) assembling	Bores 250 - 400	Hexagonal wrench	22	19,6	
Screws (pos. 11 and 26) for heads assembling	Bores 250 - 400	Allen key	See table B160, section [3]	See table B160, section [3]	
Screws (pos. 9) for rod bearing locking	Bores 250	Allen key	12	167	
	Bores 320 - 400		14	255	
Grub screw air bleed (pos. 33)	Bores 250 - 400	Allen key	4	6	
Calibration of piston seal	Bores 250 - 400	KP - XX	According to the bore size	-	
Calibration of rod seals	Bores 250 - 400	KR - XX	According to the bore size	-	

3 SPARE PARTS CODES

3.1 Seals

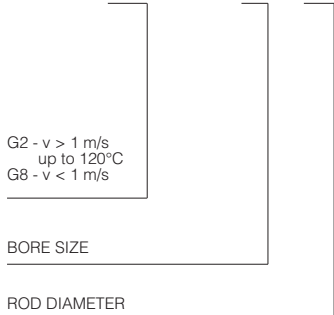
ORDER CODE	POS	DESCRIPTION	G2	G8
G8 - CH - 250 / 140  G2 - v > 1 m/s up to 120°C G8 - v < 1 m/s BORE SIZE ROD DIAMETER	2	Wiper - PTFE	•	•
	3	Rod guide ring - phenolic resin	•	•
	4	Rod seal - PTFE	• [2]	• [2]
	5	Rod guide ring - phenolic resin	• [2]	• [2]
	6	O-Ring + Anti-extrusion ring - rod bearing	•	•
	12	Anti-extrusion ring - cylinder housing	• [2]	• [2]
	13	O-ring - cylinder housing	• [2]	• [2]
	17	Screw stop pin - piston/rod	•	•
	19	O-Ring + Anti-extrusion ring - piston/rod	•	•
	20	Piston seal - PTFE	•	•
	21	Piston guide ring - PTFE	• [3]	• [3]
	27	O-Ring + Anti-extrusion ring	•	•
	27.1	O-Ring + Anti-extrusion ring	•	•
28	Bonded seal	•	•	

3.2 Rod bearing

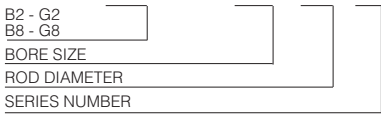
ORDER CODE	POS	DESCRIPTION	G2	G8
B1 - CH - 250 / 140 - 20  B2 - G2 B8 - G8 BORE SIZE ROD DIAMETER SERIES NUMBER	2	Wiper - PTFE	•	•
	3	Rod guide ring - phenolic resin	•	•
	4	Rod seal - PTFE	• [2]	• [2]
	5	Rod guide ring - phenolic resin	• [2]	• [2]
	8	Rod bearing	•	•

3.3 Piston rod

ORDER CODE	POS	DESCRIPTION	G1	G8
U - CH - 250 / 140 x 500...  COMPLETE CYLINDER CODE + SERIES NUMBER	1	Rod	•	•
	15	Front cushioning piston (if selected)	•	•
	16	Rear cushioning piston (if selected)	•	•
	17	Screw stop pin - piston/rod	•	•
	18	Piston	•	•
	19	O-Ring + Anti-extrusion ring - piston/rod	•	•
	20	Piston seal - PTFE	•	•
	21	Piston guide ring - PTFE	• [3]	• [3]
	34	Rear ring cushioning piston	•	•
	35	Screw stop pin	•	•

3.4 Cushioning

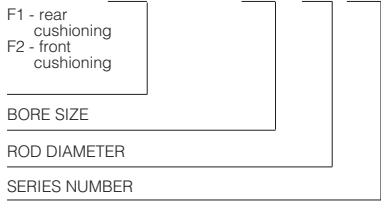
ORDER CODE	POS	DESCRIPTION	Front F2	Rear F1
F1 - CH - 250 / 140 - 20  F1 - rear cushioning F2 - front cushioning BORE SIZE ROD DIAMETER SERIES NUMBER	15	Front cushioning piston	•	
	16	Rear cushioning piston		•
	23	Toroidal ring		•
	24	Rear cushioning sleeve		•
	27	O-Ring + Anti-extrusion ring	•	•
	27.1	O-Ring + Anti-extrusion ring	•	•
	28	Bonded seal	•	•
	29	Cushioning adjustment plug	•	•
	30	Cushioning adjustment screw	•	•
	31	Seeger	•	•
	34	Rear ring cushioning piston		•
	35	Screw stop pin		•